



IO-Link

Huba Control

Relative and absolute pressure transmitter Type 528 IO-Link



 **IO-Link**

The compact type 528 pressure transmitter is based upon the well proven ceramic technology developed by Huba Control over 20 years ago.

Huba Control offers with the Type 528 a universally applicable pressure transmitter with IO-Link communication technology. IO-Link is a standardized, digital point-to-point connection that allows the user to easily wire the unit and access a wide range of specific device and process data. IO-Link offers numerous possibilities for device diagnostics, allowing the status of the pressure transmitter to be continuously monitored. This makes the 528 IO-Link the ideal pressure transmitter for your Industry 4.0 application.

Pressure range
-1 ... 0 – 60 bar

- + Compact, rugged construction
- + Communication via IO-Link 1.1 (Smart Sensor Profile ED2)
- + Sensor diagnosis function
- + High flexibility of process connections

Technical overview

Pressure range

Relative	-1 ... 0 – 60 bar
Absolute	0 ... 1 – 16 bar

Operating conditions

Medium			Liquids and gases
Temperature	Medium	FPM	-15 ... +100 °C
		EPDM	-40 ... +100 °C
		NBR	-20 ... +100 °C
		MVQ	-40 ... +100 °C
		FPM	-40 ... +100 °C
	Ambient		-30 ... +85 °C
	Storage		-50 ... +100 °C
Tolerable overload / Rupture pressure		≤ 4 bar	3.0 x fs
		> 4 bar	2.5 x fs

Materials

Cover		Stainless steel 1.4404 / AISI 316L
Plug accommodation		Polyarylamide 50% GF UL 94 V-0
Materials in contact with medium	Pressure connection	Stainless steel 1.4404 / AISI 316L
		PVDF
	Sensor	Ceramic Al ₂ O ₃ (96%)
	Sealing material	FPM, EPDM, NBR, MVQ

Electrical overview

4 wire	Output	Power supply	Permanent current load	Current consumption
Polarity reversal protection	IO-Link	18 ... 33 VDC	100 mA per switching output	< 15 mA ²⁾
Insulation voltage	Short circuit proof and protected against polarity reversal. Each connection is protected against crossover up to max. supply voltage.			500 VDC

IO-Link

Specification	V1.1
Port type	Class A
Baud rate	COM2 (38.4 k Baud)
Output function	PNP, NPN, PushPull
Programming options	Offset
	Filter
	Switching points
	Hysteresis- / filter function, N/C contact or N/O contact
	min./max. pressure value, pressure peak counter
	Operating hours counter

Dynamic response

Startup time	50 ms
Response time	typ. < 2 ms
Process cycle time	< 3.3 ms
Load cycle	< 100 Hz

Electrical connection

Connector M12x1	Protection standard	Protection class
	IP 67	III

Pressure connection

Inside thread	7/16 - 20 UNF	
	1/2 - 14 NPT	
	G 1/4	with O-Ring seal FPM (-30 ... +135 °C)
	7/16 - 20 UNF	sealing cone
Outside thread	1/4 - 18 NPT	
	7/16 - 20 UNF	sealed at back SAE 4 with O-Ring seal FPM (-20 ... +135 °C)
	G 1/4, G 1/2, G 3/8	sealed at back DIN EN ISO 1179-2 with Profile seal ring in FPM (-30 ... +135 °C)
	G 1/4, G 1/2	sealed at back and manometer (combi) with Profile seal ring in FPM (-30 ... +135 °C)
	G 1/4	sealed at back DIN 3852-2 form A
	R 1/4	EN 10226
	1/8 - 27 NPT	
	G 1/8	sealed at front or sealed at back and manometer (combi) with Profile seal ring in FPM (-30 ... +135 °C)
	M10x1	sealed at back DIN EN ISO 1179-2 with Profile seal ring in FPM (-30 ... +135 °C)
	M20x1.5	sealed at front and manometer (combi)
G 1/4, G 1/2	sealed at front	

Installation arrangement

Unrestricted

Tests / Admissions

Electromagnetic compatibility	CE conformity acc. EN 61326-2-3
Enhanced EMC protection	EN 50121-3-2
Shock acc. IEC 68-2-27	100 g, 11 ms half sine wave, all 6 directions, free fall from 1 m on concrete (6x)
Constant shock acc. IEC 68-2-29	40 g for 6 ms, 1000x all 3 directions
Vibration acc. IEC 68-2-6	20 g, 15 ... 2000 Hz, 15 ... 25 Hz with amplitude ± 15 mm, 1 Octave/min. all 3 directions, 50 constant load
UL	ANSI/UL 61010-1 acc. E325110
EAC	

Weight

~ 90 g

Packaging (Please state on order)

Single packaging in cardboard	accessories integrated
Multiple packaging in cardboard (25 pcs)	

¹⁾ without switching output

²⁾ typ.; max. 25 mA

Accuracy

Parameter		Unit	
Characteristic line a ¹⁾		% fs	± 0.3
Resolution		% fs	0.1
Thermal characteristic ²⁾	max.	% fs/10K	± 0.2
Long term stability acc. EN 60770-1	max.	% fs	± 0.25

Test conditions: 25 °C, 45% RH, power supply 24 VDC

Order code selection table in bar				1	2	3	4	5	6	7	8	9	10	
				528.	X	X	X	X	X	X	X	X	X	
Pressure range (relative) ³⁾	-1 ... 0 bar			9	0	1								
	0 ... 1 bar			9	1	1								
	0 ... 1.6 bar			9	1	2								
	0 ... 2.5 bar			9	1	4								
	0 ... 4 bar			9	1	5								
	0 ... 6 bar			9	1	7								
	0 ... 10 bar			9	3	0								
	0 ... 16 bar			9	3	1								
	0 ... 25 bar			9	3	2							1	
	0 ... 40 bar			9	3	3							1	
0 ... 60 bar			9	4	0							1		
Pressure range (absolute) ³⁾	0 ... 1 bar			8	1	1								
	0 ... 1.6 bar			8	1	2								
	0 ... 2.5 bar			8	1	4								
	0 ... 4 bar			8	1	5								
	0 ... 6 bar			8	1	7								
	0 ... 10 bar			8	3	0								
	0 ... 16 bar			8	3	1								
Sealing material	FPM	Fluoro elastomer	(-15 ... +100 °C)					0						
	EPDM	Ethylene propylene						1						
	NBR	Butadiene Acrylonitrile						2						
	MVQ	Silicone polymer						3						
	FPM	Fluoro elastomer	(-30 ... +100 °C)					5						
Application	standard							0						
Output / power supply	IO-Link	18 ... 33 VDC							L					
Electrical connection	M12x1	4L: L+ = 1 / L- = 3 / C/Q = 4 / DI/DQ = 2								P				
Pressure connection ³⁾	Inside thread	7/16-20 UNF sealing cone										K	1	
		1/2 -14 NPT										D	1	
		G 1/4 with O-Ring seal FPM										1	1	
	Outside thread	7/16-20 UNF sealing cone											2	1
		1/4 -18 NPT											3	1
		G 1/4 sealed at back DIN EN ISO 1179-2 with profile seal ring in FPM											4	1
		G 1/4 sealed at back and manometer with profile seal ring in FPM											5	1 1
		R 1/4 acc. to EN 10226											7	1
		G 1/2 sealed at back and manometer with profile seal ring in FPM											8	1
		7/16-20 UNF sealed at back SAE 4 with O-Ring seal FPM											G	1
		1/8 - 27 NPT											A	1
		G 1/8 sealed at front											M	1
		G 1/8 sealed at back DIN EN ISO 1179-2 with Profile seal ring in FPM											H	1
		G 1/4 sealed at front											J	1
		G 1/4 sealed at back DIN 3852-2 form A ⁴⁾											S	1
		G 1/2 sealed at back DIN EN ISO 1179-2 with profile seal ring in FPM											C	1
		M10x1 sealed at back DIN EN ISO 1179-2 with profile seal ring in FPM											F	1
		M20x1.5 sealed at front and manometer (combi)											E	1
		G 1/2 sealed at front											9	
Pressure orifice	without												1	
	with												2	
Material	Stainless steel 1.4404 / AISI 316L												1	
pressure connection	PVDF outside thread ⁴⁾	sealed at front G 1/4, G 1/2	≤ 16 bar								J,9	1	2	

¹⁾ typ. ; max. 0.5% fs (incl. zero point, full scale, linearity, hysteresis and repeatability)
⁴⁾ without UL admission

²⁾ -15 ... 85 °C

³⁾ Other pressure ranges or pressure connections on request

³⁾ Medium temperature -15 ... +85 °C

Corner-wire box for connector M12x1 with cable 2.0 m	114604
Straight-wire box for connector M12x1 with cable 2.0 m	114605
Mounting bracket with screw	118716
Heat sink with outside thread G 1/2 sealed at front - inside thread G 1/2	105631
Heat sink with outside thread G 1/2 sealed at front - inside thread G 1/4	105073
Heat sink with outside thread G 1/4 sealed at front - inside thread G 1/4	105074
Calibration certificate	104551

Mounting bracket with screw

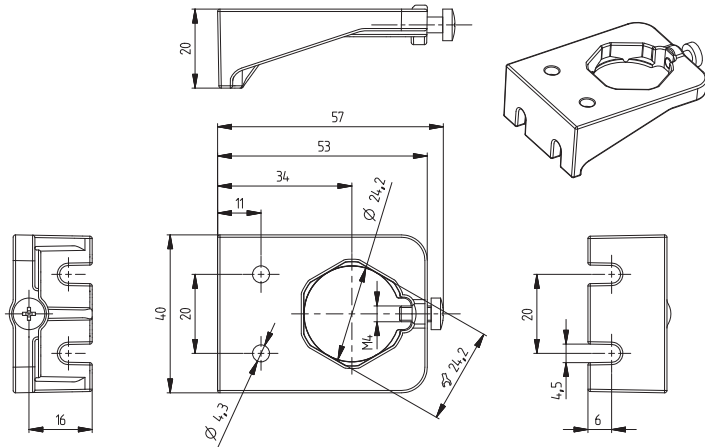

Heat sink

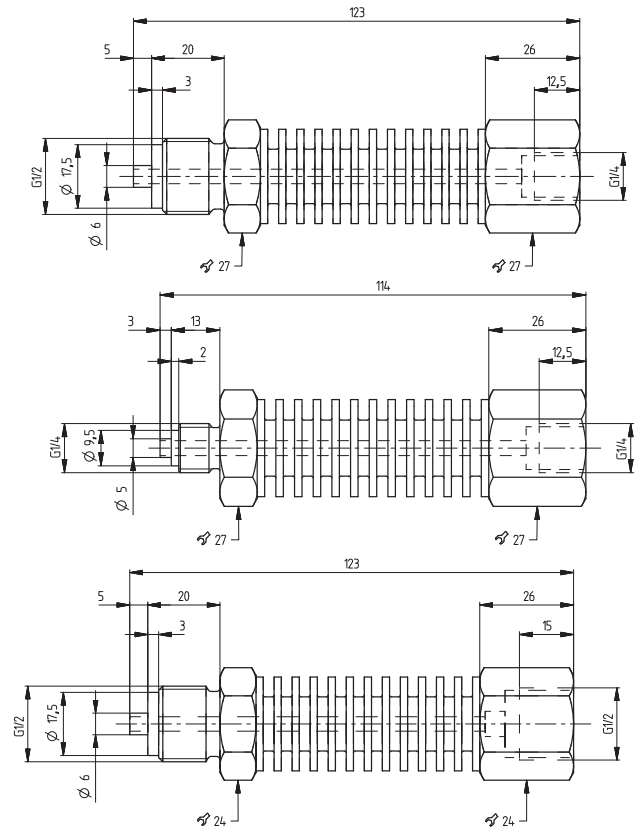

Dimensions in mm

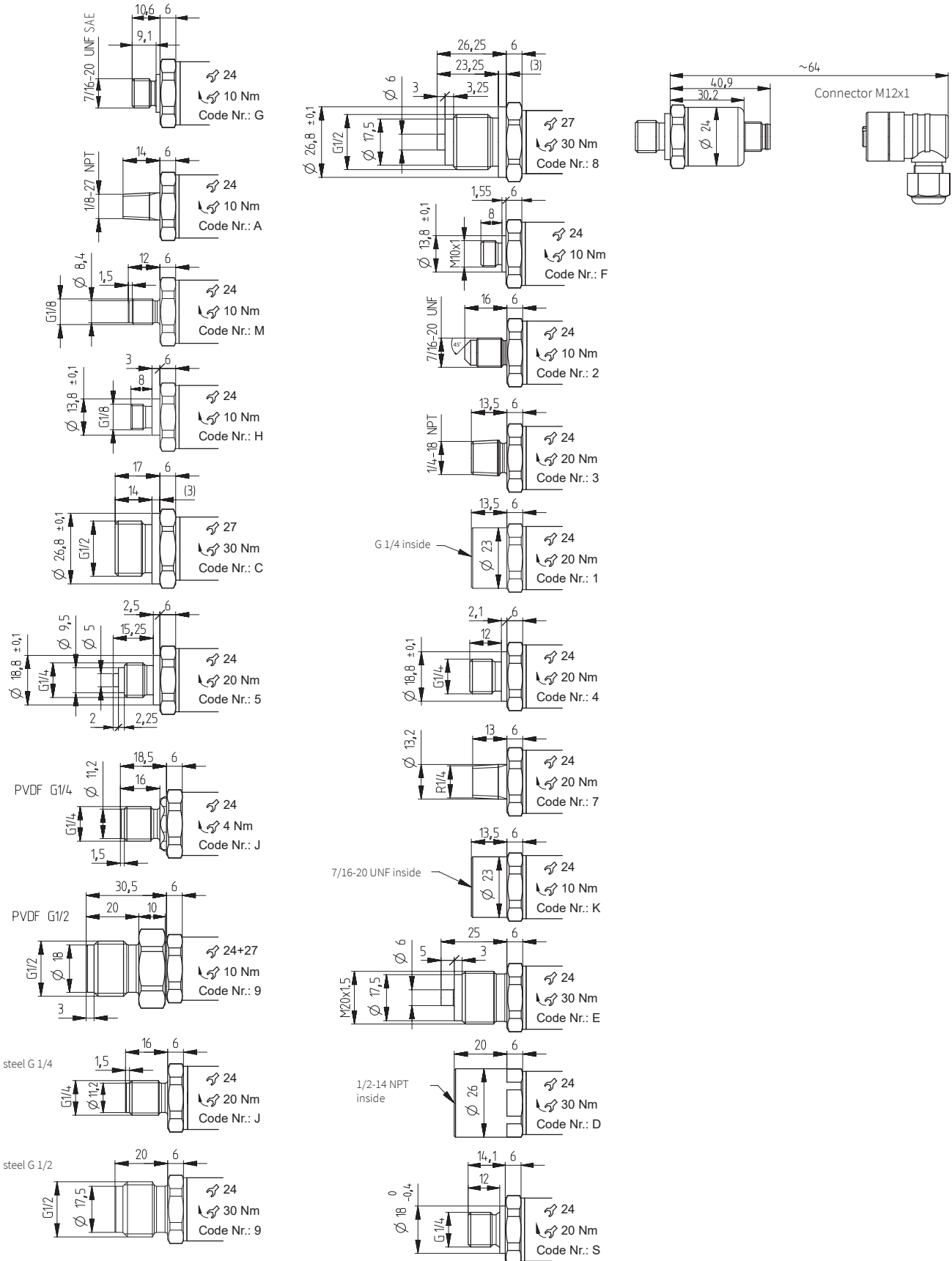

Electrical connections

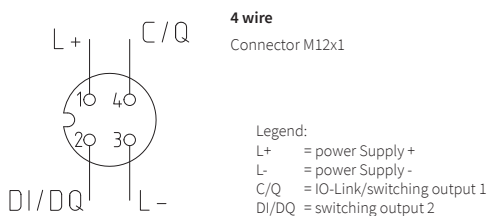

Huba Control AG

Headquarters Schweiz
Industriestrasse 17
CH-5436 Würenlos
Telefon +41 56 436 82 00
Fax +41 56 436 82 82
info.ch@hubacontrol.com

Huba Control AG

Vestiging Nederland
Hamseweg 20A
NL-3828 AD-Hoogland
Telefoon +31 33 433 03 66
Telefax +31 33 433 03 77
info.nl@hubacontrol.com

Huba Control AG

Niederlassung Deutschland
Schlattgrabenstrasse 24
D-72141 Walddorfhäslach
Telefon +49 7127 2393 00
Fax +49 7127 2393 20
info.de@hubacontrol.com

Huba Control USA, Inc.

Office United States of America
303 Wyman Street
Suite #300
Waltham MA 02451
Tel: +1 866-6HUBACO (+1 866-648-2226)
info.usa@hubacontrol.com

Huba Control SA

Succursale France
Rue Lavoisier
Technopôle Forbach-Sud
F-57602 Forbach Cedex
Téléphone +33 3 87 84 73 00
Télécopieur +33 3 87 84 73 01
info.fr@hubacontrol.com

Huba Control AG

Branch Office United Kingdom
Unit 13 Berkshire House, County Park Business
Centre, Shrivenham Road
Swindon Wiltshire SN1 2NR
Phone +44 1993 77 66 67
Fax +44 1993 77 66 71
info.uk@hubacontrol.com

www.hubacontrol.com

